

11305-07
GEORGIA AVE
WHEATON, MD



GEORGIA AVE

ELKIN ST

11307
**3,600 SF plus
2,700 SF Basement**

11305c
Unplugged Restaurant
& Sports Bar

11305b
Paul Kee Restaurant

11305
**4,000 SF plus
2,500 SF Basement**

ETHIOPLUS
11303
Caramelo
Bakery
11302

Gisele's
Creole Cuisine

PRIVATE PARKING

EMPLOYEE
PARKING

PRICE AVE

RETAIL PLAN

Site Plan Key

- Available
- Leased

11305-07
GEORGIA AVE
WHEATON, MD



DETAILS: 11307

- Street Level: 3,600 SF
- Basement: 2,700 SF
- Pylon Panel
- Builtout Office/Retail Opportunity



3,600 SF

2,700 SF

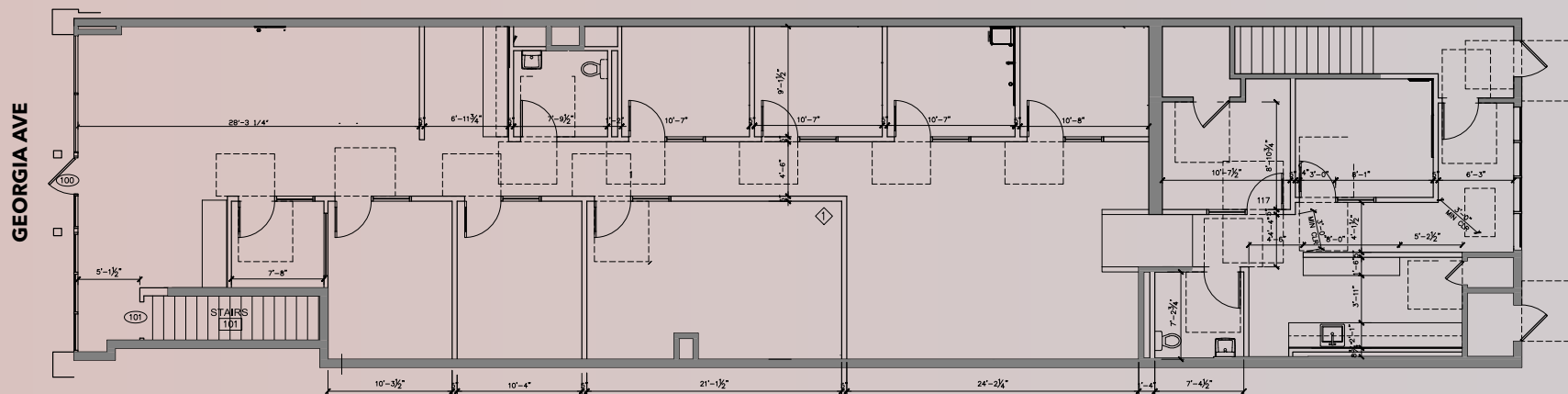

1ST FLOOR PLAN

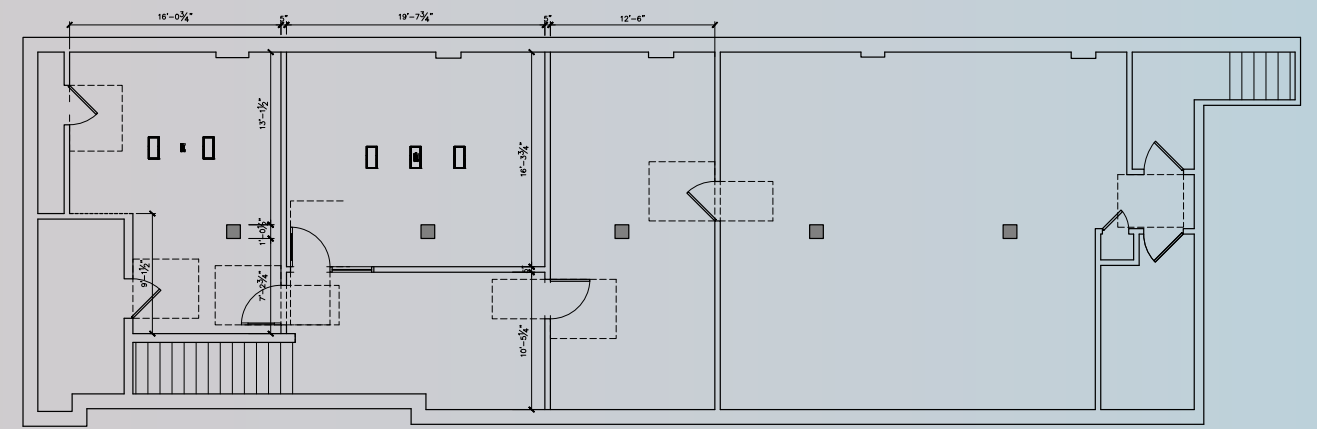

BASEMENT

11305-07
GEORGIA AVE
WHEATON, MD



DETAILS: 11305

- Street Level: 4,000 SF
- Basement: 2,500 SF
- Pylon Panel
- Builtout Office/Retail Opportunity



Additional Parking in Rear



1ST FLOOR PLAN



BASEMENT